

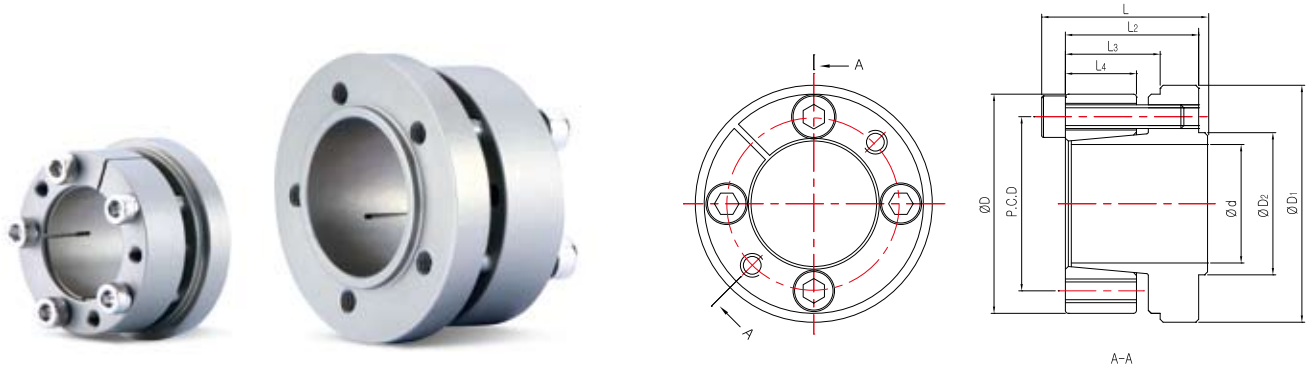

# SAPC SERIES : SAPC



## Dimensions / Performance

Model d x D	Size (±0.3mm)							Max. Permissible Torque(Tc) (N·m)	Max. Permissible Thrust Load(Pt) (kN)	Surface Pressure (Mpa)		screw(locking bolt)			Mass(g)
	L	L <sub>2</sub>	L <sub>3</sub>	L <sub>4</sub>	D <sub>1</sub>	D <sub>2</sub>	P.C.D			Shaft(Pi)	Hub(Po)	Size	The no. of screws	Fastening Torque(N·m)	
SAPC-5-16	15.5	13	9	6.5	19	7.5	11.1	2.5	1	121	35	M2.5	2	1.3	7
SAPC-6-17	15.5	13	9	6.5	20	8.5	12.1	4	1.33	151	49	M2.5	3	1.3	8
SAPC-8-19	17.5	15	10	7.5	22	11	14.1	6	1.51	129	51	M2.5	4	1.3	11
SAPC-10-21	17.5	15	10	7.5	24	13	16.1	8	1.63	104	46	M2.5	4	1.3	12
SAPC-11-22	19.5	17	11	8	25	14	17.1	9	1.66	88	41	M2.5	4	1.3	14
SAPC-12-24	20.5	18	12	9	27	15	19.2	12	1.99	89	42	M2.5	5	1.3	17
SAPC-14-26	20.5	18	12	9	29	17	21.2	18	2.56	91	47	M2.5	6	1.3	19
SAPC-15-28	23	20	13	9.5	31	18.5	22.2	25	3.34	79	38	M3	4	2.3	24
SAPC-16-29	23	20	13	9.5	32	19.5	23.2	26	3.34	74	37	M3	4	2.3	25
SAPC-17-30	24	21	14	10	33	20.5	24	27	3.18	66	34	M3	4	2.3	28
SAPC-18-31	24	21	14	10	34	21.5	25	29	3.23	78	41	M3	5	2.3	29
SAPC-19-32	24	21	14	10	35	22.5	26	33	3.5	74	40	M3	5	2.3	30
SAPC-20-37	28	24	16	12	40	24	29.4	54	5.47	92	46	M4	4	5.1	47
SAPC-22-39	28	24	16	12	42	26	31.4	65	5.94	83	43	M4	4	5.1	52
SAPC-24-41	30	26	18	13	45	28	33.3	85	7.07	84	46	M4	5	5.1	57
SAPC-25-42	32	28	19	13.5	46	29	34.3	110	8.77	97	53	M4	6	5.1	67
SAPC-28-45	32	28	19	13.5	49	32	37.3	125	8.91	101	57	M4	7	5.1	73
SAPC-30-50	35	30	20	14.5	55	34.5	41.3	180	12.08	99	56	M5	5	10	101
SAPC-32-53	35	30	20	14.5	58	36.5	43.3	210	13.13	104	59	M5	6	10	112
SAPC-35-56	38	33	22.5	16	62	40	46.6	230	13.13	92	54	M5	6	10	134

- Pt(Max. Permissible Thrust Load) indicates values at the zero(0) torque, and Tc(Max. Permissible Torque) at the zero(0) thrust load respectively. In case torque and thrust load occur simultaneously, please refer to the formula in the [Selection guide] page for combined load calculation.
- For the best performance, make sure all foreign substances e.g. corrosion, dust etc. are removed from each surface of shaft, hub, and A.P. Lock's inner and outer ring.